Reach PoE Tester Manual V1.0

Model RT-PoE3N

Software Version 1.0 and above

February 2, 2010



© Copyright Reach Technology Inc. 2005-2010
All Rights Reserved

Information contained in this user documentation is subject to change without notice and does not represent a commitment on the part of Reach Technology Inc. Reach Technology Inc. assumes no responsibility or liability for any errors or inaccuracies that may appear in the user documentation.

Reach Technology, Inc.
www.reachtech.com
(510) 770-1417
sales@reachtech.com

Table of Contents

| | | |
|-----------|---|-----------|
| 1. | REVISION HISTORY | 4 |
| 1.1. | RT-PoE3N - BASE MODEL | 4 |
| 2. | GENERAL | 5 |
| 2.1. | OVERVIEW | 5 |
| 2.2. | FRONT PANEL | 5 |
| 2.3. | FEATURES..... | 6 |
| 2.4. | DIMENSIONS | 6 |
| 2.5. | ELECTRICAL CHARACTERISTICS | 6 |
| 2.6. | WARRANTY | 6 |
| 3. | CONFIGURATION GUIDE | 7 |
| 3.1. | POWER..... | 7 |
| 3.2. | SERIAL CONSOLE | 7 |
| 3.3. | UUT (UNIT UNDER TEST) AND REFERENCE CONNECTIONS | 7 |
| 4. | CONNECTORS AND JUMPERS | 9 |
| 4.1. | RJ-45 ETHERNET CONNECTORS | 9 |
| 4.2. | REAR CONNECTORS | 9 |
| 4.3. | INTERNAL ETHERNET POWER JUMPERS..... | 10 |
| 5. | OPERATIONAL OVERVIEW..... | 11 |
| 5.1. | DATA PATH | 11 |
| 5.2. | POWER INPUT | 11 |
| 5.3. | SIGNATURE AND LOADS | 12 |
| 6. | COMMAND REFERENCE | 13 |
| | HELP | 13 |
| | VERSION | 13 |
| | ERROR CHECK..... | 14 |
| | HOSTNAME | 14 |
| | BAUD | 14 |
| | ECHO | 15 |
| | BOOT | 15 |
| | PORT / GROUP PREFIX | 15 |
| | AUTO | 16 |
| | CAL | 16 |
| | CAP..... | 16 |
| | CLASS | 17 |
| | CONNECT | 17 |
| | DETECT | 17 |
| | EXT..... | 18 |
| | LOAD | 18 |
| | MEASURE | 18 |
| | RESET | 18 |
| | SET | 18 |
| | SET MPS | 19 |
| | SHORT | 19 |
| | STATUS | 20 |

| | |
|--|-----------|
| APPENDIX A - OPERATIONAL NOTES | 21 |
| A.1 POWER-ON..... | 21 |
| A.2 HIGH POWER TESTING INCLUDING IEEE 802.3AT..... | 21 |
| A.3 ERROR MESSAGES | 22 |
| APPENDIX B - TEST SETUPS..... | 23 |
| B.1 OVERVIEW | 23 |
| B.2 SIGNATURE DETECT..... | 23 |
| B.3 CLASS DETECT..... | 23 |
| B.4 POWER STATUS AND OVERLOAD (IEEE 802.3AF) | 24 |
| B.5 DATA TRANSMISSION UNDER POWER..... | 24 |
| B.6 IEEE 802.3AT..... | 25 |
| APPENDIX C - SPECIFICATIONS | 26 |
| C.1 MEASUREMENT SPECIFICATIONS..... | 26 |

1. Revision History

1.1. *RT-PoE3N - Base Model*

The Model RT-PoE3N is the initial version in production. It can be recognized by the version string as follows (see version command; also seen on power-on).

```
Reach PoE Tester Model RT-PoE3N Rev HW 1.0 SW 1.00/1  
12/15/2009
```

2. General

2.1. Overview

Manufacturers of Ethernet Power Sourcing Equipment (PSE) such as Ethernet Switches need to test PoE power functionality during manufacturing. Once a unit is in manufacturing, it can be assumed that it has already been tested for full Compliance with the applicable IEEE 802.3 PoE standard. It is not cost-effective, nor necessary, to perform compliance testing at the manufacturing stage. What is needed is a functional test that verifies the software's ability to detect and control power, and the basic connectors' and magnetics' ability to provide power and pass data.

The Reach RT-PoE tester family has been designed for cost-effective functional production test. It assumes that the PSE can be operated in a “diagnostic” mode whereby the power control and detection functions of the PSE can be individually tested. The LLPD protocol specified by the 802.3at standard is not supported so as to keep the cost of the tester low.

The Reach Power-over-Ethernet Tester Model RT-PoE3N provides diagnostic functional testing of 24 PSE ports compatible with IEEE Standards 802.3af and 802.3at. It can draw up to 720mA per port while passing gigabit traffic. It provides high density with 24 Powered Device (PD) loads in a 1U high chassis.

Each RT-PoE section has a “UUT” and a “REF” port. The UUT port is connected to the PSE and acts as a PD load to that port. The UUT datapath is connected via power-isolating magnetics to the REF port. In this way, an external data bit error tester or PSE test functionality can be used to test data integrity while power load is enabled.

2.2. Front panel



Picture 1: Front of RT-PoE3N

2.3. Features

- ◆ Emulates legacy Cisco IP phone signature
- ◆ Flexible IEEE signature options: low, nominal, high, over-spec capacitive
- ◆ Classification including margins
- ◆ Passes GbE traffic from UUT to REF port isolated from PD load
- ◆ Relay datapath for compatibility with Phy-based cable diagnostics
- ◆ Low cost compared to compliance-level PD emulators
- ◆ Universal voltage (110/220) power supply
- ◆ Serial RS232 console control

2.4. Dimensions

The unit fits in a standard 19" rack using screw-on ears.

Case outside dimensions are:

14.75" deep
17.30" wide
1.74" high

2.5. Electrical Characteristics

The RT-PoE3N is powered via a barrel connector and requires 12V DC at a maximum of 3.75 Amps.

The unit is supplied with a worldwide universal AC input power supply brick. Its characteristics are:

90-264VAC input, 82% efficient, 0 to 40C operation, IEC320/C14 input

2.6. Warranty

The RT-PoE3N is warranted by Reach Technology Inc. against manufacturing defects for one year.

3. Configuration Guide

3.1. Power

The power input is located on the rear of the unit. The power supply provided is a "desktop" type brick with a three prong IEC input connector. An AC power cord compatible with U.S. power outlets is provided. There is no power switch; it is on when the power is applied.

3.2. Serial Console

The serial console port is located at the rear of the unit. It is an RJ-45 with a three-wire RS-232 level interface. The interface has the same pinout as found on Cisco routers and switches. The baud rate factory default is 9600, 1 stop, no parity, 8 bits. The baud rate can be changed by software command – see Section 6. Characters are echoed as they are typed (full duplex).

RJ-45 Connector:

| Pin | Signal (DTE name) |
|-----|-------------------------|
| 1 | ** |
| 2 | ** |
| 3 | RS232 data output (TxD) |
| 4 | Ground |
| 5 | Ground |
| 6 | RS232 data input (RxD) |
| 7 | ** |
| 8 | ** |

** these signals are connected to each other

3.3. UUT (Unit Under Test) and Reference connections

The RT-PoE3N has twenty-four identical test ports. Each port has a UUT and a REF connector. Connect the port of the PoE supplying device under test to the UUT connector via a standard straight through Ethernet connector. Connect the REF port to the device that will do traffic tests to the UUT. This may require a crossover cable; the UUT to REF datapath connection is 1-to-1. There is an 802.3at class transformer isolating the UUT port from the REF port so that power can be tapped from the UUT. All datapath connections are made via signal relays and 100 ohm differential pairs for data integrity.

Note that the device connected to the REF port cannot "see" the power from the UUT port. In other words, the UUT port connects to the REF port from a data perspective and the UUT port connects to the RT-PoE3N active load from a power (PoE) perspective.

NOTE: with high power loads, the DC balance of the patch cables used is important to avoid DC saturation of the Ethernet transformers. DC Balance (DC resistance per side of the power carrying pair) should be within 3%. The standard patch cable specifications of Cat 5, 5e, and 6 do not specify DC balance.

4. Connectors and Jumpers

4.1. RJ-45 Ethernet connectors

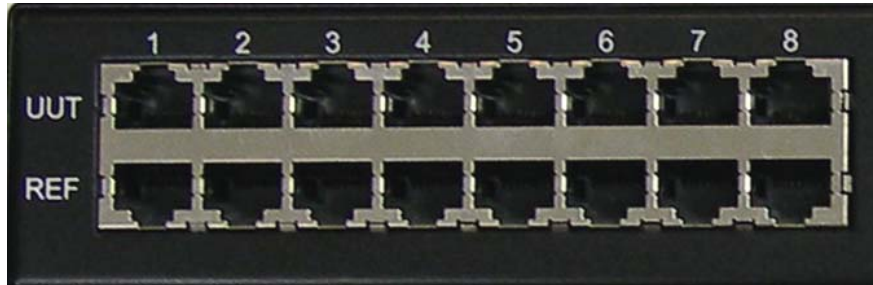

Picture 2: Far left side of RT-PoE3N front panel

The UUT connector should be cabled to the corresponding PSE port using a standard Ethernet 1-1 jumper cable. When enabled via software command, the data component of the UUT port will be connected to the REF connector below it. This is a straight-through connection, not a crossover.

4.2. Rear Connectors



Picture 3: Far left side of RT-PoE3N rear panel

The rear of the unit, left side is shown above. The power jack is a standard "Barrel" type with inside pin diameter of 2.5mm. Center pin positive, 12VDC. Below that is a console connector RJ45 three wire RS232. See Section 2.2 for pinout.

4.3. Internal Ethernet Power Jumpers

A 6 position header and two jumpers are provided for each test port to determine which pair provides the power from the UUT. The following Table corresponds to Table 33-1 of the IEEE 802.3af specification. (802.3at has the same table.) **The unit is shipped in Type 1 mode.** Note that only two jumpers are to be installed for each port.

| Conductor | Type 1: (MIDI-X) | Type 2: (MIDI) | Type 3: (AII) |
|-----------------|---|--|-------------------------------------|
| 1 | Negative Vport | Positive Vport | |
| 2 | Negative Vport | Positive Vport | |
| 3 | Positive Vport | Negative Vport | |
| 4 | | | Positive Vport |
| 5 | | | Positive Vport |
| 6 | Positive Vport | Negative Vport | |
| 7 | | | Negative Vport |
| 8 | | | Negative Vport |
| Install Jumpers | Bottom 2 pair: Pins 9-10 Pins 11-12 | Middle 2 pair: Pins 5-6 Pins 7-8 | Top 2 pair: Pins 1-2 Pins 3-4 |

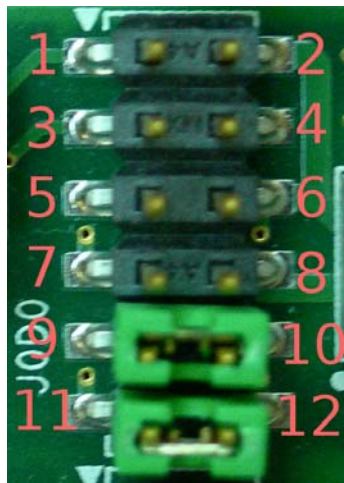

Port 1 Jumper block shown.

Jumpers 9-10 and 11-12 installed by default.

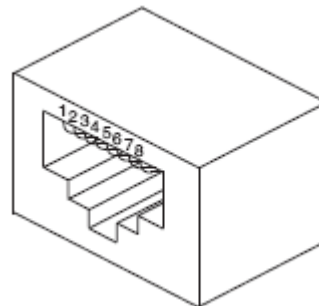

5. Operational Overview

5.1. Data path

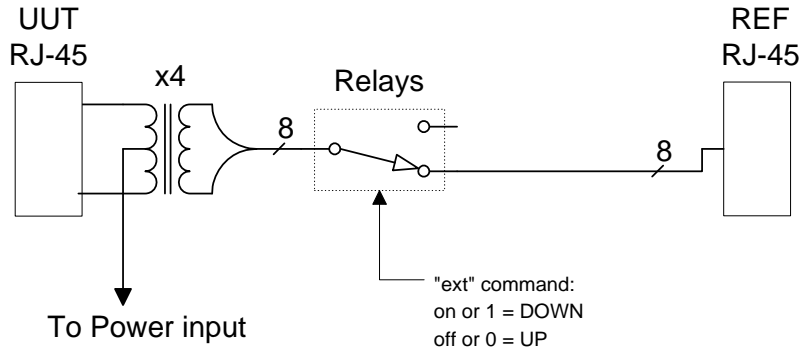

The data path section allows the UUT port to be connected to the Reference device, or to be disconnected as shown above.

5.2. Power input

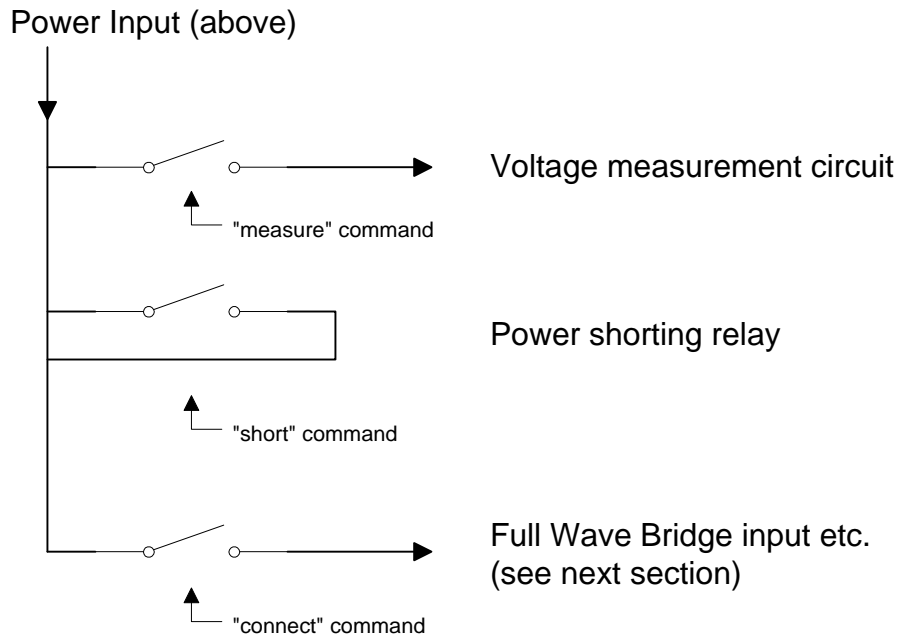

The power from the UUT can be measured, shorted, or connected to the Full Wave Bridge and subsequent load circuits.

5.3. Signature and loads

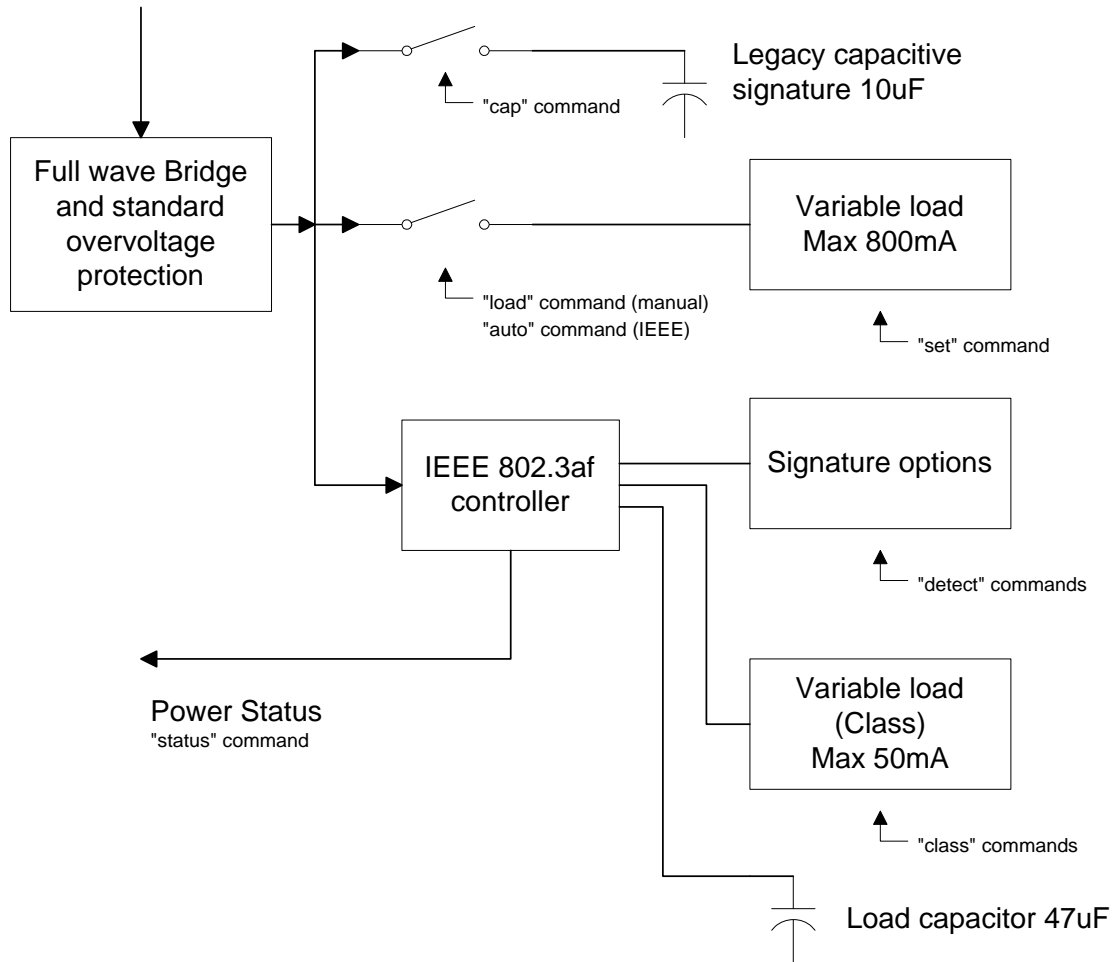

The IEEE 802.3af controller used is the TI TPS2375.

The variable power load can be connected directly to the full wave bridge for emulation of non-IEEE loads. There are full signature resistor options for IEEE - too low, nominal, too high, and none. A legacy capacitive load can be applied; this can also be used to simulate an AC load for AC disconnect testing. The classification load is variable and can be margined. The "power-good" status of the IEEE controller goes active once the load capacitor is charged and can be monitored.

6. Command Reference

This section describes the commands available. For typical command sequences, see Appendix B.

When the unit is ready for a command, it issues the prompt "RT-PoE3N>". Command buffering is not supported; you must wait for the prompt before sending a command. The prompt may be changed via the "hostname" command. The default baud rate is 9600. This can be changed via the "baud" command.

All commands are terminated by a <return> which is the character 0x0D (decimal 13).

Most commands have a short form version. The optional characters of a command are indicated by the [] brackets.

All commands that take "on" or "off" arguments can also take "1" and "0" as arguments.

Responses from the unit that include variable data such as the port number are shown as 'C' printf style strings, so the script writer knows exactly what to expect as a response.

HELP

| | |
|-------------|------------------------------|
| Description | Displays available commands. |
| Command: | he[lp] |
| Command: | ? |
| Example: | help |

VERSION

| | |
|-------------|--|
| Description | Displays software and hardware version |
| Command: | vers[ion] |
| Result: | "Reach PoE Tester Model RT-PoE3N Rev HW 1.0 SW 1.00/X 12/15/2009\r\n" |

The X indicated the version of software on the line cards. An error is generated if the line card versions are inconsistent.

ERROR CHECK

Description: The unit maintains an error flag that is set if any error message is generated. This command reports the error flag value. A test script can run an entire sequence of commands and check at the end to make sure there were no errors instead of having to check on a command-by-command basis.

Command: `err[ors]`

Result: `"1 - one or more errors have occurred; error flag
reset\r\n"`

or

`"0 - no errors have occurred\r\n"`

HOSTNAME

Description: Used to change the unit's prompt. This is useful in a production system so the script knows exactly which physical unit it is talking to. Name must be equal or less than 31 characters long

Command: `host[name] <string>`

Example: `hostname myTester`

This makes the unit's prompt "myTester>"

BAUD

Description: Used to change the unit's baud rate. This will not take effect until the unit power is cycled or the *boot command is issued. This is done to make sure the baud change is acceptable.

Command: `*baud <baudrate>`

`<baudrate> = 9600, 19200, 38400, 57600, or
115200`

Example: `baudrate 19200`

Response: `"Console baud set to %lu. Cycle power or issue
*boot to effect change.\n"`

ECHO

| | |
|--------------|---|
| Description: | Used to test the communication between the host and this unit. This is useful at higher baud rates to validate a baud can be used without error. A script can repeat the echo command continuously and verify that no communication errors are present. |
| Command: | <pre>*echo <string> <string> = any ascii string. May contain spaces.</pre> |
| Example: | <pre>echo this is a test</pre> |
| Response: | <pre>"this is a test\n"</pre> |

BOOT

| | |
|-------------|--|
| Description | Resets the system to the power-on state. This is the same as if the unit has its power cycled. |
| Command | <pre>*boot</pre> |

PORT / GROUP PREFIX

| | |
|---------------|---|
| Description | For all port-specific commands, a port or group prefix will restrict the command to a specific port or port group. The prefix must be followed by a space before the port command. If no prefix is used, the command will be applied to all 24 ports. |
| Port Prefix: | <pre>pN</pre> <p>This specified port N where N is from 1 to 24.</p> |
| Group Prefix: | <pre>gM</pre> <p>This specifies group M where M is from 1 to 3.</p> <p>group 1 = ports 1-8 group 2 = ports 9-16 group 3 = ports 17-24</p> |

AUTO

Description Auto-enables the power load when the IEEE "power good" signal becomes active.

Note: Use the auto command to automatically turn the load on after the inrush period after power is supplied by the PSE.

Command: auto [on|off]

Response: printf(":p%d auto %d\r\n", port, state);
state = 1 or 0 for on and off respectively.

CAL

Description Runs internal calibration of class and power loads.

Command: cal

Response: printf(":p%d Autocal OK\r\n", port);
or
printf("!p%d Autocal FAIL\r\n", port);

CAP

Description Controls the 10uF capacitor across the full-wave bridge. This represents either a legacy capacitive signature or an AC load.

Command: cap [on|off]

Response: printf(":p%d cap %d\r\n", port, state);
state = 1 or 0 for on and off respectively.

CLASS

Description Sets the IEEE load class. See IEEE 802.3af specification.

Command: `cl[ass] [0|1|2|3|4][+|-|>|<]`

Arguments:

- `+` margin up 5%
- `-` margin down 5%
- `>` margin up 10%
- `<` margin down 10%

Response: `printf(":%p%d class %d%c\n", port, class, margin);`

Example: `p9 cl 3+`

Example response: `:%p9 class 3+<CR><LF>`
This sets port 9 IEEE "class" to 3 with a 5% margin up.

CONNECT

Description Controls the relay that connects all power load circuitry to the UUT. When connect is off, the full wave bridge is disconnected and the UUT sees no power circuitry connected to the GbE magnetics' center taps. Connect must be on for the UUT to see an IEEE 802.3af load.

Command: `conn[ect] [on|off]`

Response: `printf(":%p%d Connect Sig %d\n", port, state);`
`state = 1 or 0 for on and off respectively.`

DETECT

Description Sets the IEEE 802.3af detect signature.

Command: `det[ect] [off|lo|ok|hi]`

Arguments:

- `off` no detect signature resistance
- `lo` signature resistance 15K 1%
- `ok` signature resistance 24.9K 1%
- `hi` signature resistance 36K 1%

Response: `printf(":%p%d det %s\n", port, arg);`

EXT

Description Controls the external reference port (REF). When off, the reference port is disconnected. When on, the reference port is connected to the UUT but only if the Cisco signature is off.

Command: `ext[ernal] [on|off]`

Response: `printf(":p%d Ext Ref %d\n", port, state);`
`state = 1 or 0 for on and off respectively.`

LOAD

Description Controls the power load connected to the output of the full wave bridge. The value of the load is determined by the SET command. This is typically used only with legacy non-IEEE PSEs.

Command: `load [on|off]`

Response: `printf(":p%d load %d\n", port, state);`
`state = 1 or 0 for on and off respectively.`

MEASURE

Description Measures the voltage from the UUT (center taps of GbE magnetics). Note that the polarity must be correct via the jumpers (Section 3.2) for this measurement to be valid. **Note: Measuring the voltage while data is passing through the port can cause data errors.**

Command: `meas[ure]`

Response: `printf(":p%d %d.%01dV\n", port, v1, v1);`
where v1 is 0 to 60 and v1 is 0 to 9.

Example: `p1 meas`

Example response: `:p1 50.5V<CR><LF>`

RESET

Description Resets port to fully disconnected state.

Command: `res[et]`

Response: `printf(":p%d reset\n", port);`

SET

Description Sets power load value in milliamps. If too low, the minimum value will be set; if above 800mA an error will occur.

Command: `set <value>`

Response: `printf(" :p%d %dmA\n", port, value);`
 or
`printf(" :p%d %dmA (min)\n", port, value);`

Example: `g2 set 350`

Example response: `:p9 350mA<CR><LF>`
`:p10 350mA<CR><LF>`
`:p11 350mA<CR><LF>`
`:p12 350mA<CR><LF>`
`:p12 350mA<CR><LF>`
`:p14 350mA<CR><LF>`
`:p15 350mA<CR><LF>`
`:p16 350mA<CR><LF>`

SET MPS

Description Sets a “maintain power signature” in which the load is cycled between the set value and a minimum (under 5mA) value. This informs the PSE that the load is valid but is using a duty cycle of less than 100% to save power. On time and off time are specified in milliseconds.

Command: `set <value> mps <on time> <off time>`

Response: `printf(" :p%d %dmA MPS on %dms, off %dms\n", port, value);`

Example: `g2 set 10 mps 60 240`

Example response: `:p9 10mA MPS on 60ms off 240ms<CR><LF>`
`:p10 10mA MPS on 60ms off 240ms <CR><LF>`
`:p11 10mA MPS on 60ms off 240ms <CR><LF>`
`:p12 10mA MPS on 60ms off 240ms <CR><LF>`
`:p12 10mA MPS on 60ms off 240ms <CR><LF>`
`:p14 10mA MPS on 60ms off 240ms <CR><LF>`
`:p15 10mA MPS on 60ms off 240ms <CR><LF>`
`:p16 10mA MPS on 60ms off 240ms <CR><LF>`

SHORT

Description Controls a relay that can short the UUT power before the full wave bridge. **WARNING - SHORTING AT FULL POWER CAN DAMAGE UUT.**

Command: `sh[ort] [on|off]`

Response: `printf(" :p%d short %d\n", port, state);`
 state = 1 or 0 for on and off respectively.

STATUS

| | |
|-------------|---|
| Description | Returns the "Power Good" status of the IEEE load controller. The status is active when the IEEE controller is receiving power above the UVLO value and the load capacitor is charged. |
| Command: | <code>st[atus]</code> |
| Response: | <code>printf(" :p%d PWR %d\n",port, state);</code> <code>state = 1 or 0 for on and off respectively.</code> |

Appendix A - Operational Notes

A.1 *Power-on*

When the unit is powered on, it performs a self-calibration of its dynamic class and power loads. This takes around 105 seconds. While calibrating, the unit flashes the front panel LED and displays the following. The prompt "RT-PoE3N>" indicates that the unit is ready for commands.

```
RT-PoE3N>"(revision dependent version string)"  
Calibrating all ports..  
:p1 Autocal OK  
:p2 Autocal OK  
:p3 Autocal OK  
:p4 Autocal OK  
:p5 Autocal OK  
:p6 Autocal OK  
:p7 Autocal OK  
:p8 Autocal OK  
:p9 Autocal OK  
:p10 Autocal OK  
:p11 Autocal OK  
:p12 Autocal OK  
:p13 Autocal OK  
:p14 Autocal OK  
:p15 Autocal OK  
:p16 Autocal OK  
:p17 Autocal OK  
:p18 Autocal OK  
:p19 Autocal OK  
:p20 Autocal OK  
:p21 Autocal OK  
:p22 Autocal OK  
:p23 Autocal OK  
:p24 Autocal OK  
RT-PoE3N>
```

A.2 *High power testing including IEEE 802.3at*

The inrush delay mandated by IEEE 802.3at requires that a high power load (over 400mA) cannot be applied until after the 80mS inrush period. The "auto" command enforces this inrush delay.

A.3 **Error messages**

All error messages begin with the "!" exclamation mark.

| <u>Error Message</u> | <u>Description</u> |
|-----------------------------|---|
| !Syntax error | There was syntax error in the previous command. |
| !Reach PoE Tester... | There is an internal version error in this unit. |
| ! invalid port value | There value given with the port prefix was not valid. |
| ! invalid group value | There value given with the group prefix was not valid. |
| ! run calibration first | If the power-on calibration was interrupted, and the set or class commands are used, this error message is generated. |
| ! invalid class value | There CLASS command argument is not 0 thru 4. |
| ! Error: set limit is 880mA | The argument for the SET command is too large. |
| !p%d Autocal FAIL | Autocalibrate has failed on the specified port. |
| ! unsupported baud rate | Baud rate argument is invalid |
| ! invalid arguments | Command argument(s) are invalid |
| (other messages) | There are other messages that begin with an exclamation point that are internal errors. If these appear, the unit needs to be repaired. |

Appendix B - Test Setups

B.1 Overview

This Appendix gives an overview of basic test setups. No port or group prefixes are shown. PSE, PD as defined in IEEE 802.3af. The RT-PoE commands are issued in the order shown.

B.2 Signature Detect

| RT-PoE commands: | PSE check after commands issued |
|---------------------|--|
| reset connect on | Verify that the PSE does not see a PD. |
| detect ok | Verify that the PSE does recognize a valid PD. |
| detect hi | Verify that the PSE does not see a PD. |
| detect lo | Verify that the PSE does not see a PD. |
| detect ok cap on | Verify that the PSE does not see a PD. |

B.3 Class Detect

| RT-PoE commands: | PSE check after commands issued |
|---|--|
| reset connect on detect ok class 0 | Verify that the PSE sees a "class 0" PD. |
| class 1 | Verify that the PSE sees a "class 1" PD. |
| class 2 | Verify that the PSE sees a "class 2" PD. |
| class 3 | Verify that the PSE sees a "class 3" PD. |
| class 4 | Verify that the PSE sees a "class 4" PD. |

B.4 Power Status and overload (IEEE 802.3af)

| RT-PoE commands: | PSE action |
|--|---|
| reset connect on detect ok class 0 set 20 auto on | |
| | Enable power to port Verify that PSE sees that device powers up. |
| status (verify that power is on) | |
| measure (verify that voltage is as expected) | |
| set 350 | (Verify that PSE is providing full power) |
| set 390 | (Verify that PSE sees overload and shuts off power) |
| status (verify that power is off) | |

B.5 Data transmission under power

| RT-PoE commands: | Check after commands issued |
|---|---|
| reset connect on detect ok class 0 set 350 auto on | |
| | Enable power to port Verify that PSE sees that device powers up. |
| status (verify that power is on) | |
| ext on | Run traffic between UUT and REF port. Verify no errors. |

B.6 *IEEE 802.3at*

This is the same as B.3 and B.4 above, but set class to 4 for high power classification and set up to 600mA for data transmission and up to 800mA for overload.

Appendix C - Specifications

C.1 *Measurement Specifications*

| | |
|-----------------------------|--|
| Voltage Measurement | $\pm 2\%$ or $\pm 0.5V$ whichever is greater |
| Current setting, power load | $\pm 2\%$ or $\pm 2mA$ whichever is greater 5mA load guaranteed less than 5mA 10mA load guaranteed greater than 10mA |
| Current setting, class load | $\pm 2\%$ or $\pm 0.5mA$ whichever is greater |

All specifications subject to change at any time without notice.